

CAN-PCI/266

Passive 66-MHz PCI-CAN Interface

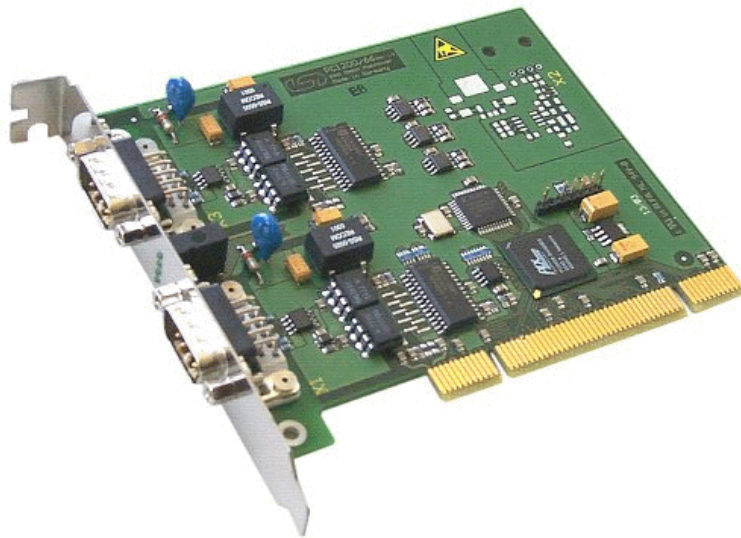

Hardware Installation and Technical Data

Document file:	I:\texte\Doku\MANUALS\CAN\PCI\266\Englisch\PCI-266_11H.ma9
Date of print:	22.08.2003

Described PCB version:	CAN-PCI/266 Rev. 1.0
-------------------------------	----------------------

Changes in the Chapters

The changes in the user's manual listed below affect changes in the **hardware**, as well as changes in the **description** of the facts only.

Chapter	Changes versus previous version
6.	Chapter 'Correctly Wiring Electrically Isolated CAN Networks' revised

Further technical changes are subject to change without notice.

NOTE

The information in this document has been carefully checked and is believed to be entirely reliable. **esd** makes no warranty of any kind with regard to the material in this document, and assumes no responsibility for any errors that may appear in this document. **esd** reserves the right to make changes without notice to this, or any of its products, to improve reliability, performance or design.

esd assumes no responsibility for the use of any circuitry other than circuitry which is part of a product of **esd gmbh**.

esd does not convey to the purchaser of the product described herein any license under the patent rights of **esd gmbh** nor the rights of others.

esd electronic system design gmbh
Vahrenwalder Str. 207
30165 Hannover
Germany

Phone: +49-511-372 98-0
Fax: +49-511-372 98-68
E-mail: info@esd-electronics.com
Internet: www.esd-electronics.com

USA / Canada

esd
PMB 292
20423 State Road 7 #F6
Boca Raton, Florida 33498-6797
USA

Phone: +1-800-732-8006
Fax: +1-800-732-8093
E-mail: sales@esd-electronics.com

Contents

1. Overview	3
1.1 Description of the Module	3
1.2 PCB View and Position of the Connectors	4
2. Hardware Installation	5
3. Summary of Technical Data	7
3.1 General Technical Data	7
3.2 PCI-Bus	7
3.3 CAN Bus	8
3.4 Software Support	8
3.5 Order Information	9
4. Front Panel View with LED Display	10
5. Connector Assignment of the CAN Interfaces	11
5.1 CAN Interface at DSUB9 Connector	11
5.2 Option: DeviceNet-Interface	12
6. Correctly Wiring Electrically Isolated CAN Networks	13

This page is intentionally left blank.



1. Overview

1.1 Description of the Module

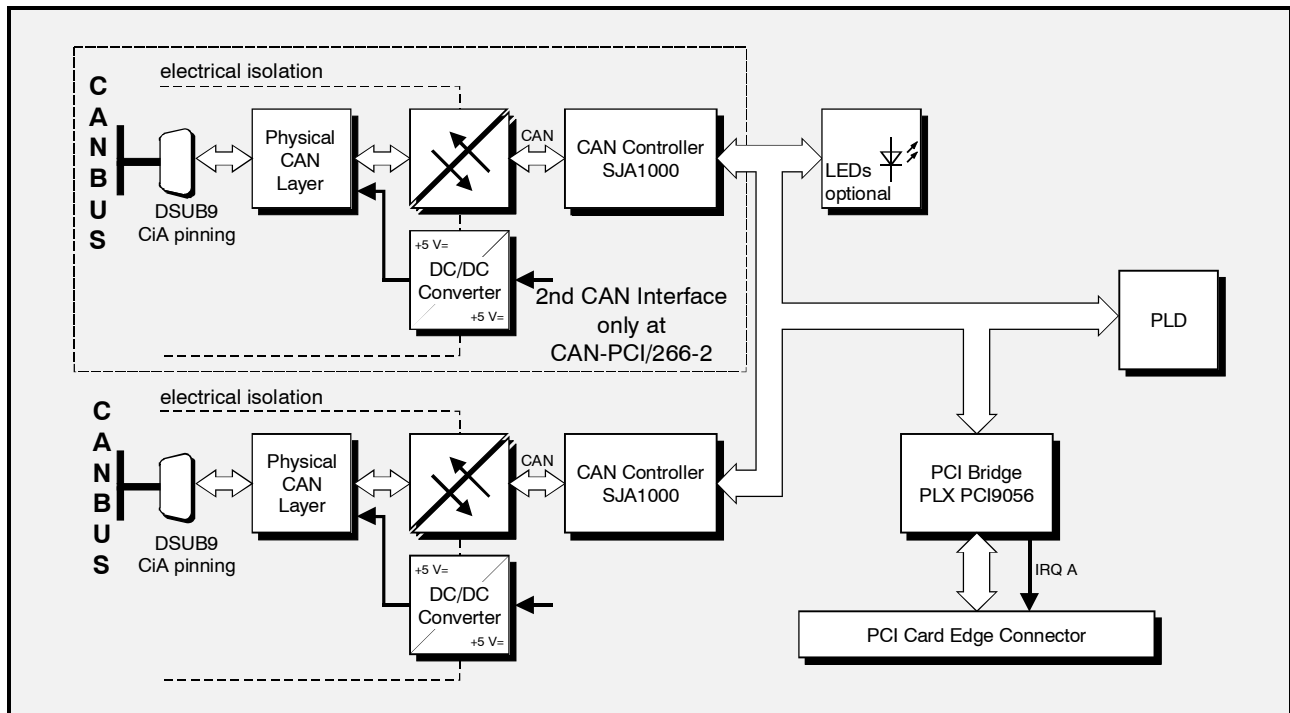

Fig. 1.1: Block circuit diagram of CAN-PCI/266

The CAN-PCI/266 is a passive PCI-bus board for 66 MHz PCI-bus systems with one or optional two CAN-interfaces. The CAN-PCI/266 works with a bus width of 32 bits. The module can also be used in 33 MHz PCI-bus systems at a bus speed of 33 MHz.

The ISO 11898 compliant CAN-interfaces allow a data transfer rate of 1 Mbit/s. Among many other features the bit rate can be parametrised by software.

The CAN interface is electrically isolated from the other potentials by optocouplers and DC/DC-converters.

Optional the board can be delivered with DeviceNet interface or Single-Wire interface.

The CAN-PCI-266-2 (with two CAN-interfaces) is equipped with four LEDs in the front panel.



1.2 PCB View and Position of the Connectors

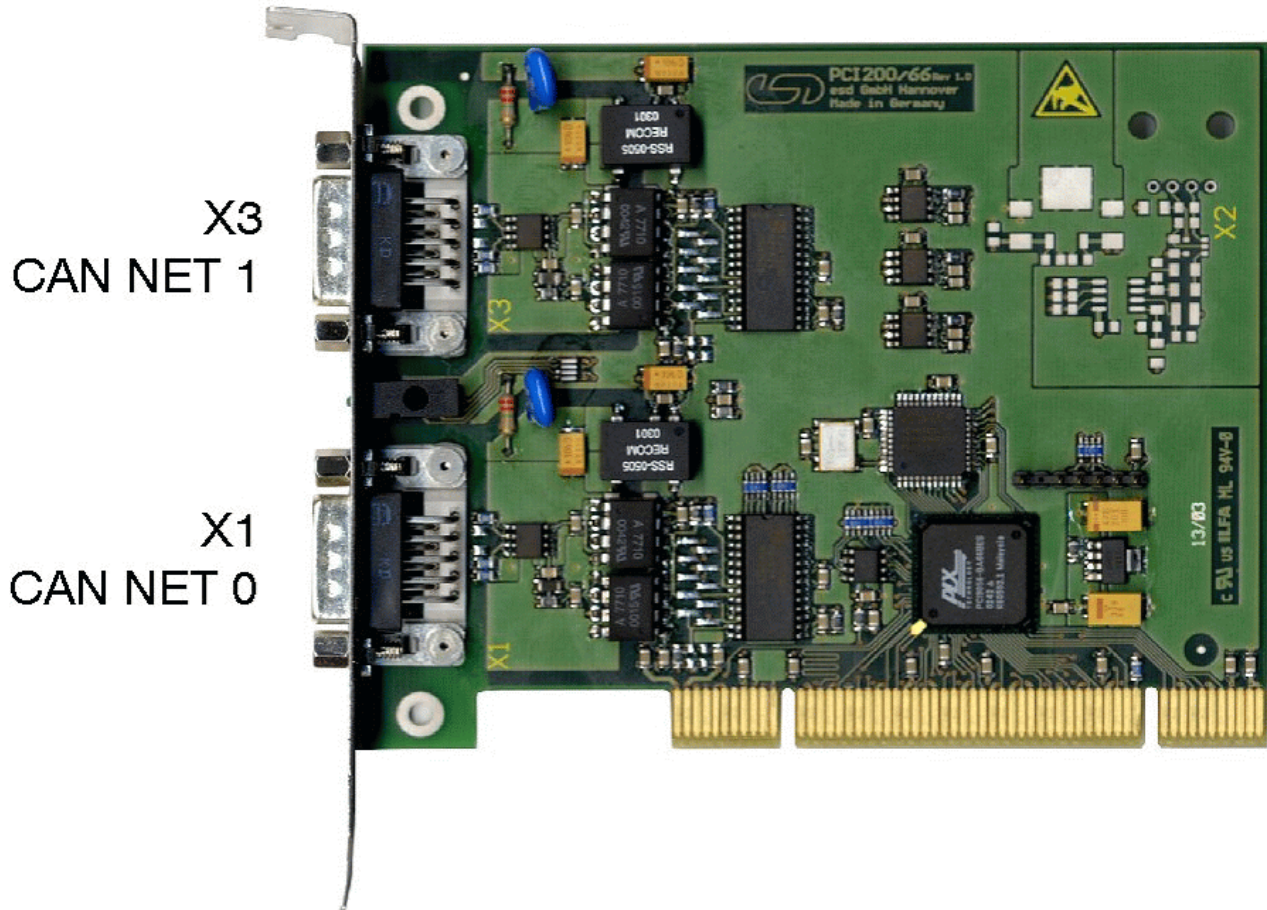
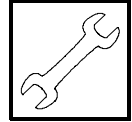

Fig. 1.2: Top layer view of the module with 2x CAN (CAN net 1 optional)



2. Hardware Installation

Attention!

Electrostatic discharge may cause damage to electronic devices. In order to avoid this please follow the instructions below *before* you touch the CAN module to discharge your personal static electricity:

- Switch off the power supply of your PC but leave the connector plug in the socket.
- Then touch the metal case of the PC to discharge the static electricity.
- Furthermore you must avoid contact between your clothes and the CAN module.

Execute Hardware Installation:

1. Switch off the PC and all connected peripheral devices (monitor, printer, etc.). Switch off the CAN devices of the net to which the CAN module is to be connected.
2. Discharge yourself as described above.
3. Disconnect the power supply of the PC from the mains.
4. Remove the PC cover.
Unfasten the mounting screws at the back of the PC and remove the cover.
5. Select an open PCI slot and remove the slot cover at the back of the PC. Unfasten the screw which fixes the slot cover and retain it for fixing the module afterwards.
The CAN module can be inserted into every PCI slot. Be careful not to insert the board into an ISA slot, because this can damage the PC and the board!
6. Insert the CAN module into the selected PCI slot.
Carefully push the board down until it snaps into place.
7. Attach the board.
Use the screw you removed from the slot cover in step 5.
8. Replace the PC cover.
Secure the cover with the screws you removed in step 4.



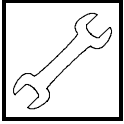

Installation

9. Connect the CAN wire.

Please note that the CAN bus has to be terminated at both ends!

esd offers special T- connectors and terminator connectors. Additionally the CAN_GND signal has to be connected to earth at **exactly one** point. For easier wiring the termination connectors are equipped with an earth connector (4.8 mm fast-on, male).

A CAN participant without an electrically isolated interface acts as an earth connection.

The first CAN interface (CAN net 0) has to be connected via the lower DSUB connector (X1) and the second CAN interface (CAN net 1) has to be connected via the upper DSUB connector (X3).

10. Reconnect the power supply of the PC.
11. Switch on the PC, the peripheral devices and the other CAN participants in any order.
12. End of hardware installation.
Continue with the software installation as described in the manual 'CAN-API, with Software Tools and Installation Notes'.

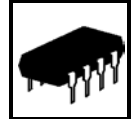

3. Summary of Technical Data

3.1 General Technical Data

Ambient temperature	0...50°C
Humidity	90 %, non-condensing
Supply voltage	via PCI-bus, Nominal voltage / current (typ., at 20°C): 5 V ±5% / 0,16 A (2x CAN) 3,3 V ±5% / 0,17 A
Plug- and socket connectors	X1 (DSUB9/male) - CAN Net 0 X3 (DSUB9/male) - optional CAN Net 1 X100 (card edge) - PCI-bus
Dimensions	99,1 mm x 120 mm (board only)
Weight	100 g (2 x CAN)

Table 3.1: General technical data of the module

3.2 PCI-Bus

Host bus	PCI bus according to PCI Local Bus Specification 2.2
PCI bus width	32 bit
PCI bus clock rate	66 MHz / 3.3V signalling level or 33 MHz / 5.0V signalling level
Controller	PLX PCI9056
Interrupt	Interrupt Signal A
Slot position	no restrictions for the position of the CAN-PCI/266 on the PCI bus, PCI bridges are tolerated
Board dimensions	compatible with all 'short' PCI-card slots
Connector	PCI-card edge connector

Table 3.2: PCI bus data



3.3 CAN Bus

Number	1, optional 2 CAN interfaces
CAN controller	SJA1000
CAN protocol	basic CAN 2.0A/2.0B
Physical layer	physical layer according to ISO 11898, transmission rate is programmable from 10 kbit/s to 1 Mbit/s
Termination	has to be set externally
Electrical separation of CAN interfaces from other units and from each other	separation by means of optocouplers and DC/DC-converters
DeviceNet-Option	adapter board with DeviceNet connector in Phoenix Combicon style, optocouplers and CAN driver according to DeviceNet specification 'DeviceNet Communication Model and Protocol, Rel. 2.0'

Table 3.3: CAN interface data

3.4 Software Support

The board is shipped with software examples for DOS and Windows 3.11 in source code. Moreover software drivers are available for Windows-NT, -2K, -XP, -9x, -ME and Linux. Drivers for other operating systems are available as well.

The CAN-API is described in the manual:
CAN-API with Software-Tools and Installation Notes
Order No.: C.2001.21

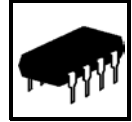

3.5 Order Information

Type	Description	Order No.
CAN-PCI/266-1	1 x CAN 2.0A/B, ISO11898	C.2036.02
CAN-PCI/266-2	2 x CAN 2.0A/B, ISO11898, LEDs	C.2036.04
CAN-DRV-LCD	Object Licence for Windows and Linux including CD-ROM	C.1101.02
CAN-PCI/266-ME	Hardware manual in English ^{1*)} (this manual)	C.2036.21
CAN-PCI/266-ENG	Engineering Manual in English ^{2*)} content: circuit diagrams, PCB top overlay, data sheets of significant components	C.2036.25
CAN-API-ME	Software manual of the CAN-API in English ^{1*)}	C.2001.21

^{1*)} If module and manual are ordered together, the manual is free of charge.

^{2*)} This manual is liable for costs, please contact our support.

Table 3.5: Order notes

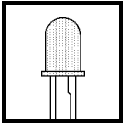

LED-Display

4. Front Panel View with LED-Display

The CAN-PCI-266 is equipped with four green LEDs in the front panel.

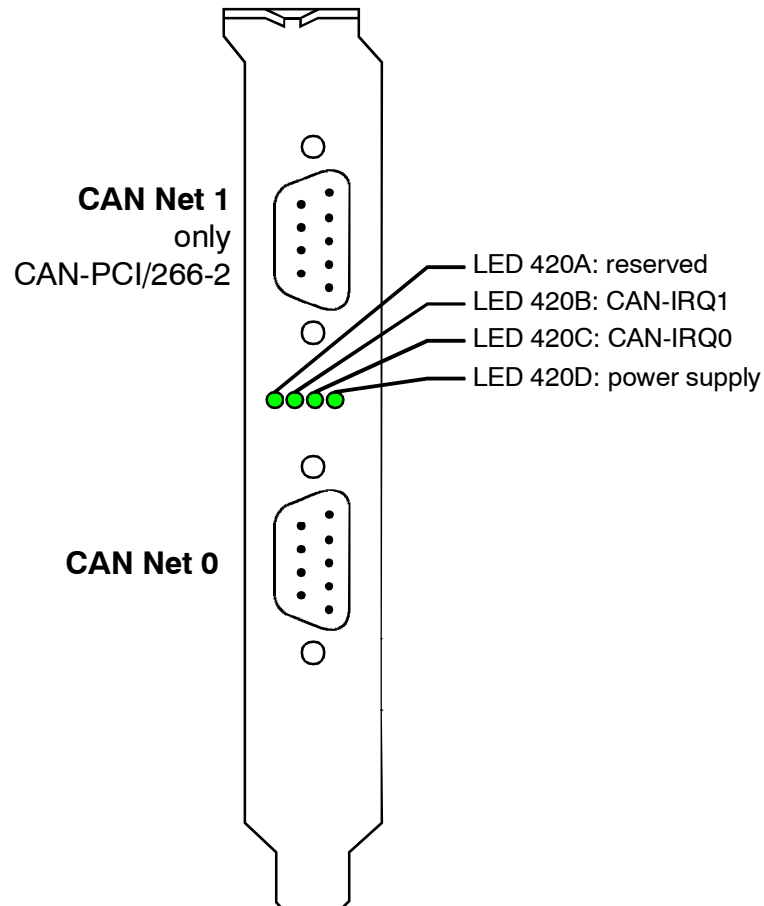
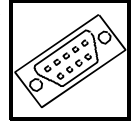

Fig.4.1: Front panel view

LED	Colour	Name	Display function (LED on)
D420A	green	ADU-CS	reserved
D420B	green	CAN-IRQ1	interrupt of CAN net 1 active - CAN frames are received or transmitted
D420C	green	CAN-IRQ0	interrupt of CAN net 0 active - CAN frames are received or transmitted
D420D	green	-	5 V- power supply on

Table 4.1: LEDs



5. Connector Assignment of the CAN Interfaces

5.1 CAN Interface at DSUB9 Connector

The assignment of the signals of the connector pins of the CAN-net 0 (X1) and the assignment of the optional CAN-net 1 (X3) are identical. The connectors are 9-pole DSUB connectors with male contacts.

Pin Position:

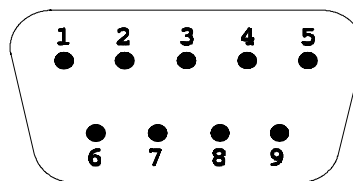

Pin Assignment:

Signal	Pin		Signal
(CAN_GND)	6	1	reserved
CAN_H		2	CAN_L
reserved	7	3	CAN_GND
reserved		4	reserved
reserved	8	5	shield
reserved		9	

9-pole DSUB connector

Signal description:

CAN_L, CAN_H...	CAN signals
CAN_GND ...	reference GND of the local CAN physical layer
(CAN_GND) ...	optional reference potential of the local CAN physical layer
reserved ...	reserved for future application
Shield...	shielding

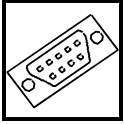

Connector Assignment

5.2 Option: DeviceNet-Interface

The DeviceNet interface is designed according to specification 'DeviceNet Communication Model and Protocol, Rel. 2.0'.

The power supply of the CAN-bus driver has to be supported from external and the connection is done via pluggable clamps of Phoenix MSTB 2,5/-GF-5,08 type (or equivalent).

Pin Position:

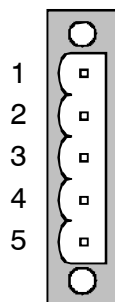

Pin Assignment:

Pin	Signal
1	V-
2	CAN-
3	Shield
4	CAN+
5	V+

signal description:

V+...	power supply ($U_{VCC} = 24\text{ V} \pm 4\%$)
V-...	reference potential to V+ and to CAN+/CAN-
CAN+, CAN-...	CAN-signals
Shield...	Shielding (via high resistance RC combination connected to earth (shield panel))

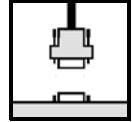

6. Correctly Wiring Electrically Isolated CAN Networks

Generally all instructions applying for wiring regarding an electromagnetic compatible installation, wiring, cross sections of wires, material to be used, minimum distances, lightning protection, etc. have to be followed.

The following **general rules** for the CAN wiring must be followed:

1.	A CAN net must not branch (exception: short dead-end feeders) and has to be terminated by the wave impedance of the wire (generally $120 \Omega \pm 10\%$) at both ends (between the signals CAN_L and CAN_H and not at GND)!
2.	A CAN data wire requires two twisted wires and a wire to conduct the reference potential (CAN_GND)! For this the shield of the wire should be used!
3.	The reference potential CAN_GND has to be connected to the earth potential (PE) at one point. Exactly one connection to earth has to be established!
4.	The bit rate has to be adapted to the wire length.
5.	Dead-end feeders have to kept as short as possible ($l < 0.3 \text{ m}$)!
6.	When using double shielded wires the external shield has to be connected to the earth potential (PE) at one point. There must be not more than one connection to earth.
7.	A suitable type of wire (wave impedance ca. $120 \Omega \pm 10\%$) has to be used and the voltage loss in the wire has to be considered!
8.	CAN wires should not be laid directly next to disturbing sources. If this cannot be avoided, double shielded wires are preferable.

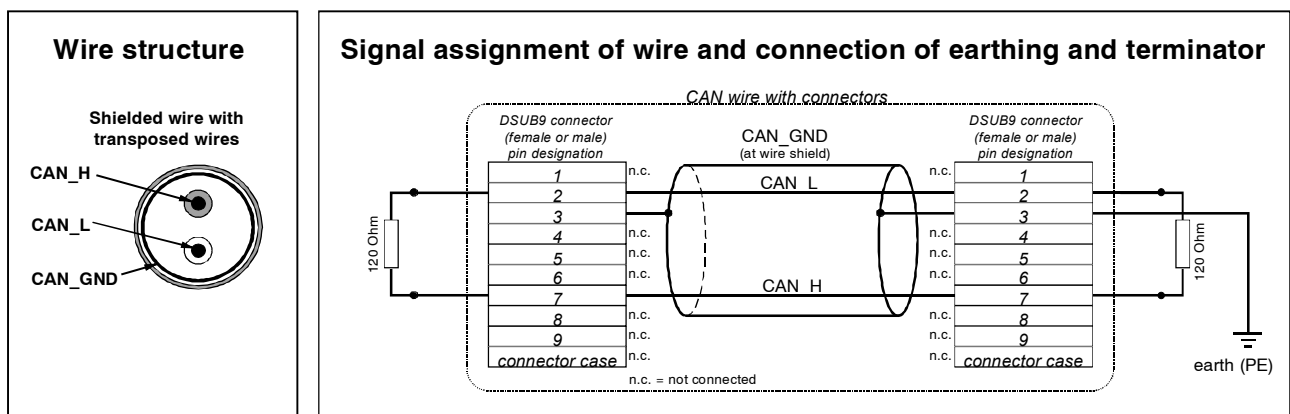
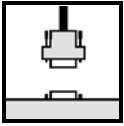

Figure: Structure and connection of wire



Wiring

Cabling

- for devices which have only one CAN connector per net use T-connector and dead-end feeder (shorter than 0.3 m) (available as accessory)

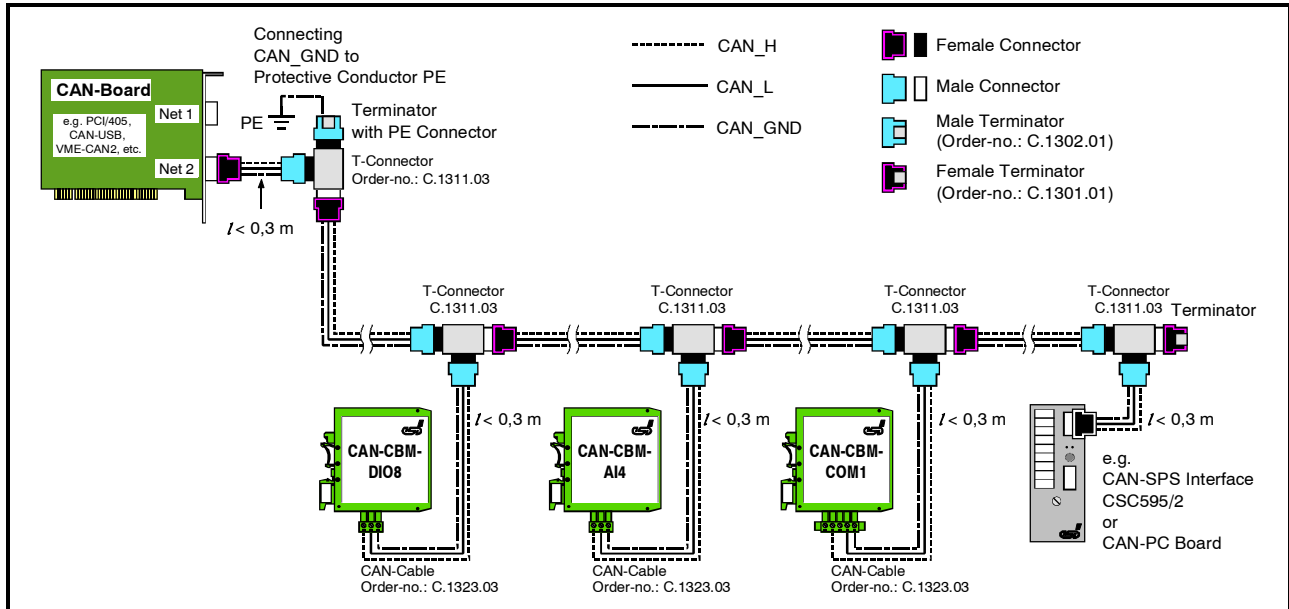

Figure: Example for correct wiring (when using single shielded wires)

Terminal Resistance

- use **external** terminator, because this CAN later be found again more easily!
- 9-pin DSUB-terminator with male and female contacts and earth terminal are available as accessories

Earthing

- CAN_GND has to be conducted in the CAN wire, because the individual esd modules are electrically isolated from each other!
- CAN_GND has to be connected to the earth potential (PE) at **exactly one** point in the net!
- each CAN user without electrically isolated interface works as an earthing, therefore: do not connect more than one user without potential separation!
- Earthing CAN e.g. be made at a connector

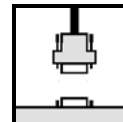

Wire Length

- Optical couplers are delaying the CAN signals. By using fast optical couplers and testing each board at 1 Mbit/s, however, esd CAN guarantee a reachable length of 37 m at 1 Mbit/s for most esd CAN modules within a closed net without impedance disturbances like e.g. longer dead-end feeders. (Exception: CAN-CBM-DIO8, -AI4 and AO4 (these modules work only up to 10 m with 1 Mbit/s))

Bit rate [kbit/s]	Typical values of reachable wire length with esd interface l_{\max} [m]	CiA recommendations (07/95) for reachable wire lengths l_{\min} [m]
1000	37	25
800	59	50
666.6	80	-
500	130	100
333.3	180	-
250	270	250
166	420	-
125	570	500
100	710	650
66.6	1000	-
50	1400	1000
33.3	2000	-
20	3600	2500
12.5	5400	-
10	7300	5000

Table: Reachable wire lengths depending on the bit rate when using esd-CAN interfaces

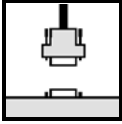

Wiring

Examples for CAN Wires

Manufacturer	Type of wire
U.I. LAPP GmbH Schulze-Delitzsch-Straße 25 70565 Stuttgart Germany www.lappkabel.de	e.g. UNITRONIC ®-BUS CAN UL/CSA (UL/CSA approved) UNITRONIC ®-BUS-FD P CAN UL/CSA (UL/CSA approved)
ConCab GmbH Äußerer Eichwald 74535 Mainhardt Germany www.concab.de	e.g. BUS-PVC-C (1 x 2 x 0,22 mm ²) Best.-Nr.: 93 022 016 (UL appr.) BUS-Schleppflex-PUR-C (1 x 2 x 0,25 mm ²) Best.-Nr.: 94 025 016 (UL appr.)
SAB Bröckskes GmbH&Co. KG Grefrather Straße 204-212b 41749 Viersen Germany www.sab-brockskes.de	e.g. SABIX® CB 620 (1 x 2 x 0,25 mm ²) Best.-Nr.: 56202251 CB 627 (1 x 2 x 0,25 mm ²) Best.-Nr.: 06272251 (UL appr.)

Note: Completely configured CAN wires can be ordered from **esd**.